

Axial Bathroom Fans

Slimline axial extractor

FUTURE-100



Slimline axial extractor designed for removal of odours and moisture from toilets, bathrooms, small offices and any small room requiring ventilation.

The FUTURE-100 provides an effective ventilation solution for wall and ceiling, non-ducted and ducted, and single or multipoint ventilation system.

- Fans manufactured from injection moulded plastic and fitted with neon light indicator
- Class II electrical insulation (□)
- IPX4
- Supply: 230V-50Hz

The fan is available with different integrated control options to accommodate all application requirements

Technical characteristics

Model type	Speed (rpm)	Maximum power absorbed (W)	Voltage (V) 50Hz	Maximum air flow (m ³ /h)	Sound pressure level (dB(A))	Insulation IP	Weight (kg)
FUTURE-100	2500	13	230	95	40	□ - IPX4	0,44

Models

Model Type	C	CT	CHT	CPIR
Neon light indicator	•	•	•	•
Adjustable Run-On-Timer		•	•	•
Adjustable humidistat			•	
PIR detector				•

Performance curve

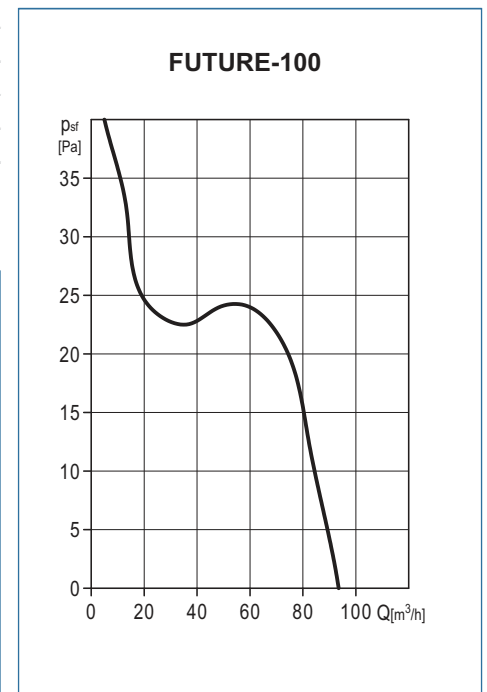

Dimensions (mm)

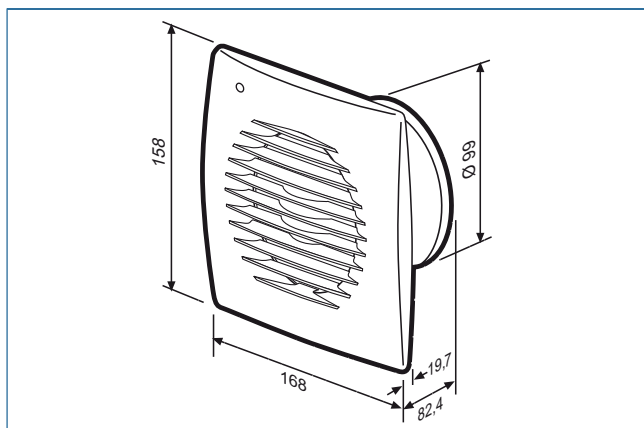

Accessories



GSA-100
Flexible aluminium duct



GRA-70
Aluminium exterior grille



PER-100W
Back draft shutter

Axial Bathroom Fans

Slimline axial extractor

FUTURE-120



Slimline axial extractor designed for removal of odours and moisture from toilets, bathrooms, small offices and any small room requiring ventilation.

The FUTURE-120 provides an effective ventilation solution for wall and ceiling, non-ducted and ducted, and single or multipoint ventilation system.

- Fans manufactured from injection moulded plastic and fitted with neon light indicator
- Class II electrical insulation (□)
- IPX4
- Supply: 230V-50Hz

The fan is available with different integrated control options to accommodate all application requirements

Technical characteristics

Model type	Speed (rpm)	Maximum power absorbed (W)	Voltage (V) 50Hz	Maximum air flow (m ³ /h)	Sound pressure level (dB(A))	Insulation IP	Weight (kg)
FUTURE-120	2500	20	230	185	45,5	□ - IPX4	0,8

Models

Model Type	C	CT	CHT
Neon light indicator	•	•	•
Adjustable Run-On-Timer		•	•
Adjustable humidistat			•
PIR detector			

Dimensions (mm)

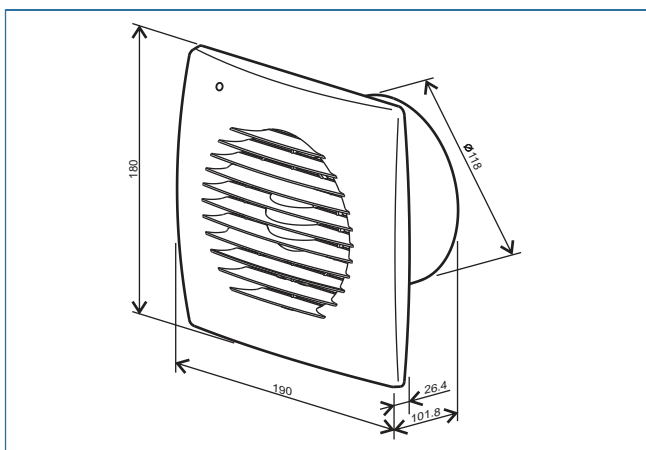

Performance curve

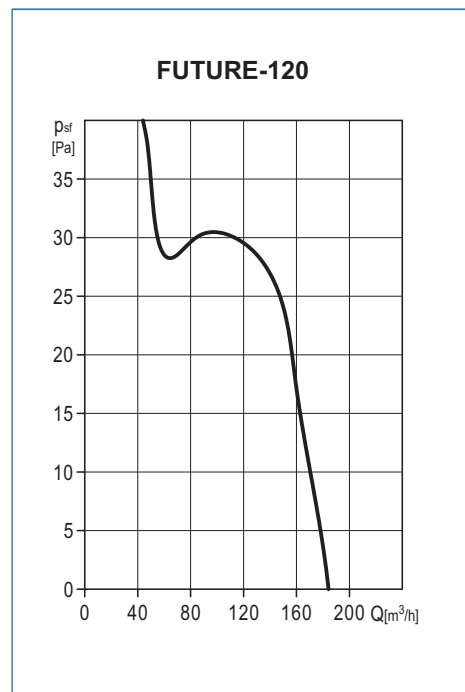

Accessories



GSA-125
Flexible aluminium duct



GRA-150
Aluminium exterior grille



PER-125W
Back draft shutter

Axial Bathroom Fans

Slimline axial extractor

FUTURE-150



Slimline axial extractor designed for removal of odours and moisture from toilets, bathrooms, small offices and any small room requiring ventilation.

The FUTURE-150 provides an effective ventilation solution for wall and ceiling, non-ducted and ducted, and single or multipoint ventilation system.

- Fans manufactured from injection moulded plastic and fitted with neon light indicator
- Class II electrical insulation (□)
- IPX4
- Supply: 230V-50Hz

The fan is available with different integrated control options to accommodate all application requirements

Technical characteristics

Model type	Speed (rpm)	Maximum power absorbed (W)	Voltage (V) 50Hz	Maximum air flow (m ³ /h)	Sound pressure level (dB(A))	Insulation IP	Weight (kg)
FUTURE-150	2200	35	230	280	47	□ - IPX4	1,44

Models

Model Type		C	T	CT
Neon light indicator	•	•	•	•
Automatic backdraft shutter		•		•
Adjustable Run-On-Timer			•	•

Performance curve

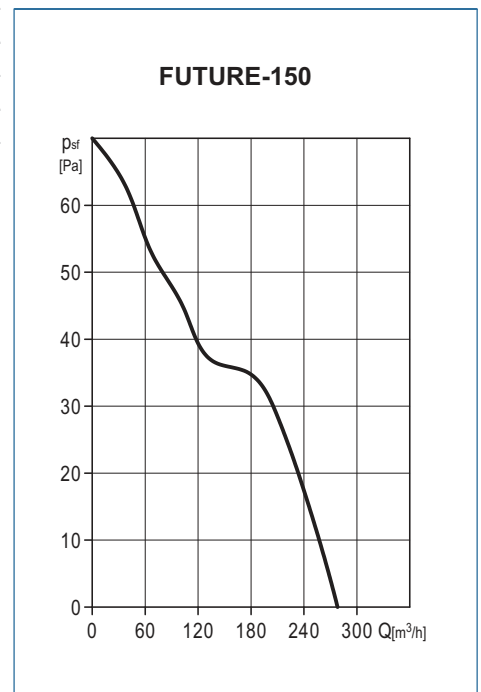

Dimensions (mm)

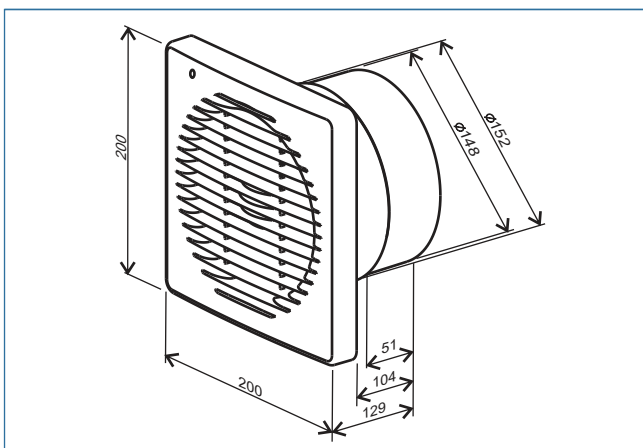

Accessories



GSA-150
Flexible aluminium duct



GRA-150
Aluminium exterior grille



PER-160W
Back draft shutter